

Standards:
 ASTM D3167 - 03
 ISO 4578 - 97
 EN 1464 - 10
 EN 2243-2

Material Type:
 ADHESIVES

Type of Testing:
 PEEL, TENSILE

FLOATING ROLLER PEEL RESISTANCE FIXTURE

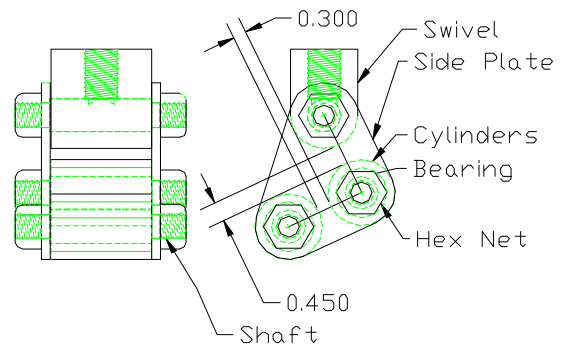

Model No.	Specimen Size or Difference Between Fixtures	Construction	Temperature
ASTM.D3167.10	1" wide, 1/4" thick and 10" long	Stainless steel	-120 to 250°F (-85 to 122°C)
ASTM.D3167.11	1.5" wide, 1/4" thick and 10" long	Stainless steel	-120 to 250°F (-85 to 122°C)
ASTM.D3167.12	6" wide, 1/4" thick and 10" long	Stainless steel	-120 to 250°F (-85 to 122°C)
ASTM.D3167.13	10" wide, 1/4" thick and 10" long	Stainless steel	-120 to 250°F (-85 to 122°C)
ISOS.04578.10	30mm wide, 2.1mm thick, 250mm long	Stainless steel	-120 to 250°F (-85 to 122°C)
ENST.02243.20	30mm wide, 2.1mm thick, 250mm long	Stainless steel	-120 to 250°F (-85 to 122°C)
ENST.01464.10	30mm wide, 2.1mm thick, 250mm long	Stainless steel	-120 to 250°F (-85 to 122°C)
DINS.53289.10	2" wide	Stainless steel	-120 to 250°F (-85 to 122°C)

Fixture:	Mounting	Top - (.10) (.11) (ISO) 1/2"-20 coupling, (.13) 3/4"-16 coupling Bottom - tensile grip (not included)
	Capacity	(.10) (.11) (ISO) 2,000 lbs, (.13) 5,000 lbs
	Weight	(.10) (.11) (ISO) 2 lbs approx., (.13) 28 lbs approx.
	Dimensions	(.10) (.11) (ISO) Assembled - 2" x 2" x 4", (.13) Assembled - 12" x 2.5" x 3"
	Standard	Manufactured in compliance with ASTM D3167, ISO 4578 EN 1464 and EN 2243-2

QUOTE

Model No. ASTM.D3167.10 - Up to 1" Wide Floating Roller Peel Resistance Fixture

The fixture will accommodate up to 1" wide test specimens. Comes with 1/2"-20 threaded coupling for upper mounting. Lower mounting requires a tensile grip that is not included. Fixture can handle 2,000 lbs capacity and weights approximately 2lbs. Constructed of stainless steel. Manufactured in compliance with ASTM D3167.

Model No. ASTM.D3167.11 - Up to 1.5" Wide Floating Roller Peel Resistance Fixture

The fixture will accommodate up to 1.5" wide test specimens. Comes with 1/2"-20 threaded coupling for upper mounting. Lower mounting requires a tensile grip that is not included. Fixture can handle 2,000 lbs capacity and weights approximately 2 lbs. Constructed of stainless steel. Manufactured in compliance with ASTM D3167.

Model No. ASTM.D3167.12 - Up to 6" Wide Floating Roller Peel Resistance Fixture

Roller Drum Peel Test Fixture with 1/2"-20 threaded adapter end. The fixture will accommodate up to 6" wide test specimens. Constructed of stainless steel. Manufactured in compliance with ASTM D3167.

Model No. ASTM.D3167.13 - Up to 10" Wide Floating Roller Peel Resistance Fixture

The fixture will accommodate up to 10" wide test specimens. Comes with 3/4"-16 threaded coupling for upper mounting. Lower mounting requires a tensile grip that is not included. Fixture can handle 5,000 lbs capacity and weights approximately 28 lbs. Constructed of stainless steel. Manufactured in compliance with ASTM D3167.

Model No. ISOS.04578.10 - Up to 30mm Wide Floating Roller Peel Resistance Fixture

The dual roller bearing type Roller Drum Peel Test Fixture is supplied with 1/2"-20 threaded coupling end. The fixture will accommodate up to 30mm wide test specimens with a 33mm peeling zone. Includes 25mm diameter rollers with bearings, side plates and all hardware necessary. Constructed of stainless steel. Manufactured in compliance with ISO 4578 and EN 2243-2.

Model No. DINS.53289.10 - Floating Roller Peel Test Fixture with 1/2"-20 threaded adapter end. The fixture will accommodate up to 2.0" wide test specimens. Constructed of stainless steel in accordance with DINS 53 289. Per specification supplied by customer. (Instron part No. P101951-1000) Capacity: 2,000 lbs (8.8 kN).

ACCESSORIES

No accessories available for this fixture

SPARE PARTS

Please contact us for spare or replacement parts

COMMON SIZE ADAPTERS

Upper Mounting: 1/2"-20 Female Threaded Coupling

Model No. M01S21 - 1/2" Male Clevis (Type B) to 1/2" -20 Threaded Stud
Model No. M02S21 - 5/8" Male Clevis (Type C) to 1/2" -20 Threaded Stud
Model No. M03S21 - 1.25" Male Clevis (Type D) to 1/2" -20 Threaded Stud
Model No. M12S21 - 12mm Male Clevis (Type O) to 1/2" -20 Threaded Stud
Model No. S36S21 - 1" -14 to 1/2" -20 Threaded Step Stud
Model No. LN21 - 1/2" -20 Threaded Locking Nut with Knurled OD

Upper Mounting: 3/4"-16 Female Threaded Coupling

Model No. M01S30 - 1/2" Male Clevis (Type B) to 3/4" -16 Threaded Stud
Model No. M02S30 - 5/8" Male Clevis (Type C) to 3/4" -16 Threaded Stud
Model No. M03S30 - 1.25" Male Clevis (Type D) to 3/4" -16 Threaded Stud
Model No. M12S30 - 12mm Male Clevis to 3/4" -16 Threaded Stud
Model No. S36S30 - 1" -14 to 3/4" -16 Threaded Step Stud
Model No. LN30 - 3/4" -16 Threaded Locking Nut with Knurled OD

EXTRA PHOTOS:

