

DOUBLE-SHEAR TEST FIXTURE WITH ALUMINUM ALLOYS WITH 1/4", 3/8", 1/2" DIAMETER INSERTS

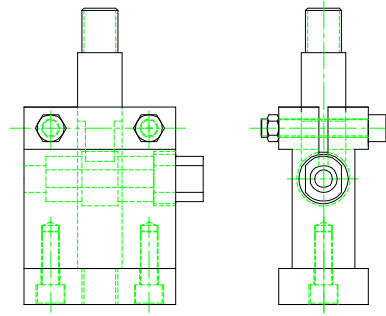

Model No.
ASTM.B0769.10

Specimen Size
1/4", 3/8" and 1/2" Diameter
Typically 3" in Length

Construction
High strength steel

Temperature
-120 to 250°F (-85 to 122°C)

Fixture:	Mounting	Top: 1"-14 stud Bottom: 1"-14 coupling
	Capacity	20,000 lbs (90kN)
	Weight	14 lbs approximately
	Dimensions	Assembled - 2" x 4" x 8"
	Standard	Manufactured in accordance with ASTM B769

QUOTE

Model No. ASTM.B0769.10 - Double-Shear Test Fixture for Aluminum Alloy

The fixture consists of a high strength load anvil that supports the aluminum test specimen at both ends with hardened and ground loading bushings. The anvil assembly is supplied with a 1.75" deep clearance section for the failed specimen and bushing. The loading anvil is supplied with a 1"-14 coupling for mounting to your test machine. The loading rod has a square section for guidance in the loading anvil and has a radiused loading end to mate with the loading bushing. The end of the loading rod is supplied with a 1"-14 threaded stud and knurled locking nut. The fixture is supplied with 3 sets of support and loading bushings for rod diameters of 1/4", 3/8" and 1/2". Bushings are hardened to 60-62 HRC. Constructed of high strength steel in accordance with ASTM B769.

ACCESSORIES

Model No. ACC.B0769.1004 - Set of (3) Bushings with 5/8" ID

Model No. ACC.B0769.1005 - Set of (3) Bushings with 3/4" ID

SPARE PARTS

Model No. SPA.B0769.1001 - Set of (3) Bushings with 1/4" ID

Model No. SPA.B0769.1002 - Set of (3) Bushings with 3/8" ID

Model No. SPA.B0769.1003 - Set of (3) Bushings with 1/2" ID

COMMON SIZE ADAPTERS

Upper Mounting: 1"-14 Threaded Stud

Model No. M03C36 - 1.25" Male Clevis to 1" -14 Threaded Coupling

Model No. S42C36 - 1.25" -12 Stud to 1" -14 Threaded Coupling

Model No. S48C36 - 1.5" -12 Stud to 1" -14 Threaded Coupling

Model No. S60C36 - 2" -12 STud to 1" -14 Threaded Coupling

Lower Mounting: 1"-14 Threaded Coupling

Model No. M03S36 - 1.25" Male Clevis to 1" -14 Threaded Stud

Model No. S42S36 - 1.25" -12 to 1" -14 Threaded Step Stud

Model No. S48S36 - 1.5" -12 to 1" -14 Threaded Step Stud

Model No. S60S36 - 2" -12 to 1" -14 Threaded Step Stud

Model No. LN36 - 1" -14 Threaded Locking Nut with Knurled OD