

## SNUBBING TYPE WIRE TENSION GRIPS - UP TO 1/4" WIRE

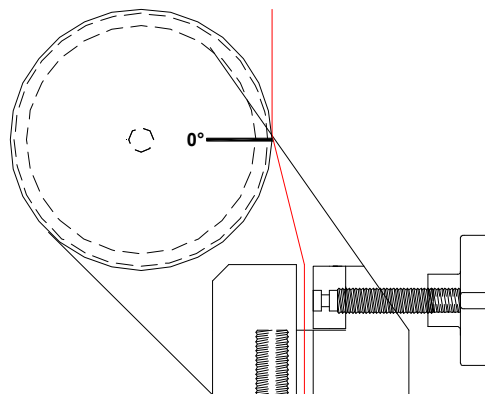

Specimen:	Diameter	1/4"
Fixture:	Construction	High strength steel with protective finish
	Temperature	-120 to 250°F (-85 to 122°C)
	Mounting	1/2"-20 threaded couplings
	Capacity	5,000 lbs
	Weight	Approximately 20 lbs
	Dimensions	2" x 12" x 2"
	Standard	Manufactured in accordance with ASTM A370 and E8

Model No. ASTM.E0008.61 - 5,000 Pound Snubbing grips

Grips that will accept Wire, Rod and Bar with diameters up to 0.25".

The grip has a stationary positive screw clamp to secure the ends of the test specimen. Supplied with 1/2"-20 threaded couplings. Constructed of high strength steel with a protective black oxide finish in accordance with ASTM A370 and E8.

## **MODEL NO. ASTM.E0008.61**

### **MECHANICAL, STEEL, ASTM, SNUBBING, WIRE,**

#### **ACCESSORIES**

**Upper and lower fixture attachment is supplied with 1/2" -20 female coupling (Common adapter sizes include:)**

Model No. M01S21 - 1/2" Male Clevis (Type B) to 1/2" -20 Threaded Stud

Model No. M02S21 - 5/8" Male Clevis (Type C) to 1/2" -20 Threaded Stud

Model No. M03S21 - 1.25" Male Clevis (Type D) to 1/2" -20 Threaded Stud

Model No. M12S21 - 12mm Male Clevis (Type O) to 1/2" -20 Threaded Stud

Model No. S36S21 - 1" -14 to 1/2" -20 Threaded Step Stud

Model No. LN21 - 1/2" -20 Threaded Locking Nut with Knurled OD

#### **SPARE PARTS**

Please contact us for spare or replacement parts.

#### **REFERENCE DOCUMENT AND TEST METHOD SCOPE:**

<http://www.astm.org/Standards/E8.htm>

ASTM E8 / E8M - 15a

Standard Test Methods for Tension Testing of Metallic Materials

1.1 These test methods cover the tension testing of metallic materials in any form at room temperature, specifically, the methods of determination of yield strength, yield point elongation, tensile strength, elongation, and reduction of area.

1.2 The gauge lengths for most round specimens are required to be 4D for E8 and 5D for E8M. The gauge length is the most significant difference between E8 and E8M test specimens. Test specimens made from powder metallurgy (P/M) materials are exempt from this requirement by industry-wide agreement to keep the pressing of the material to a specific projected area and density.

1.3 Exceptions to the provisions of these test methods may need to be made in individual specifications or test methods for a particular material. For examples, see Test Methods and Definitions A370 and Test Methods B557, and B557M.

1.4 Room temperature shall be considered to be 10 to 38°C [50 to 100°F] unless otherwise specified.

1.5 The values stated in SI units are to be regarded as separate from inch/pound units. The values stated in each system are not exact equivalents; therefore each system must be used independently of the other. Combining values from the two systems may result in non-conformance with the standard.

1.6 This standard does not purport to address all of the safety concerns, if any, associated with its use. It is the responsibility of the user of this standard to establish appropriate safety and health practices and determine the applicability of regulatory limitations prior to use.

Extracted, with permission, Standard Test Methods for Tension Testing of Metallic Materials copyright ASTM International, 100 Barr Harbor Drive, West Conshohocken, PA 19428. A copy of the complete standard may be purchased from ASTM International, [www.astm.org](http://www.astm.org).

*Material Testing Technology*