

12" SPAN, FOUR POINT FLEXURE FIXTURE FOR SPECIMENS UP TO 2" WIDE (SS)

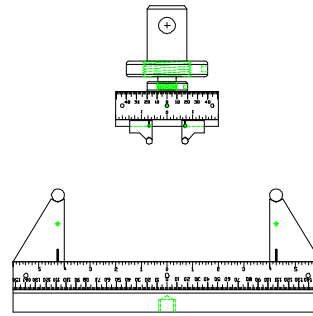
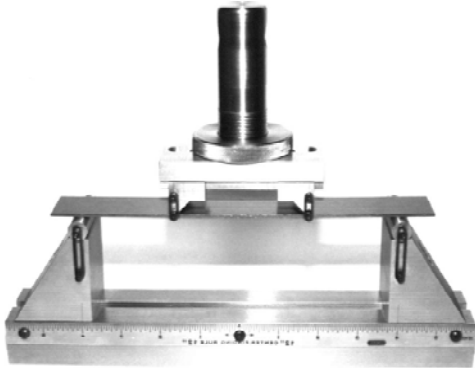

Specimen:	Width	Any width up to 2"
	Thickness	Any thickness up to 2"
	Length	Any length up to 12"
Fixture:	Construction	Stainless steel
	Temperature	-240 to 600°F (-152 to 318°C)
	Mounting	5/8" -18 threaded couplings
	Capacity	8,000 lbs (35.5 kN)
	Weight	25 lbs approximately
	Dimensions	Assembled - 3" x 13" x 9"
	Standard	Manufactured in accordance with ASTM D790 and D6272

Model No. ASTM.D6272.10 - Four Point Flexure Fixture for Plastics Specimen widths up to 2" with supports continuously adjustable from 1/2" up to 12".

Fixture is constructed of stainless steel in accordance with ASTM D790, D6272, and D7264.

Support Base - 12" long by 2" wide with a T-slot running the length of the base. The upper and lower surfaces are ground flat and parallel. The support block separation is measured along a center finding scale on the the front surface of the support base. Includes 5/8" -18 studs and locking nuts.

Specimen Supports - 2" wide by 4" tall with alignment rails which fit in the T-slotted support base. The supports are supplied with 10mm diameter loading pins which are held in alignment grooves with O-rings. The center position of the loading pin is indicated by a scribe line which runs down the side of the support to the center finding scale. The supports are free to slide anywhere along the support base and may be reversed for short and long spans.

Four Point Loading Head - Four point head is 2" wide by 6" long with two adjustable loading pin supports. The 6" long loading rail allows the pin supports to be adjusted to any loading span from 1/2" to 6". The pin supports are channeled to insure proper alignment to the loading rail. The pin supports are supplied with 10mm diameter pins which are held in an alignment groove with O-rings. The center positions of the loading pins are scribed in the pin support which runs along a center finding scale on the loading rails.

MODEL NO. ASTM.D6272.10

ASTM, FLEXURAL, UNREINFORCED,

ACCESSORIES

ACC.D6272.1001 - 1/2" Diameter Roller Set of (4)
ACC.D6272.1002 - 3/8" Diameter Roller Set of (4)
ACC.D6272.1003 - 1/4" Diameter Roller Set of (4)

Upper fixture attachment is supplied with 5/8"-18 female coupling (Common adapter sizes include:

Model No. M01S27 - 1/2" Male Clevis (Type B) to 5/8" -18 Threaded Stud
Model No. M02S27 - 5/8" Male Clevis (Type C) to 5/8" -18 Threaded Stud
Model No. M03S27 - 1.25" Male Clevis (Type D) to 5/8" -18 Threaded Stud
Model No. M12S27 - 12mm Male Clevis to 5/8" -18 Threaded Stud Adapter
Model No. S36S27 - 1" -14 to 5/8" -18 Threaded Step Stud
Model No. LN27 - 5/8" -18 Threaded Locking Nut with Knurled OD

SPARE PARTS

SPA.D6272.1001 - Extra 10mm Diameter Roller Set of (4)

REFERENCE DOCUMENT AND TEST METHOD SCOPE:

<http://www.astm.org/Standards/D6272.htm>

ASTM D6272 - 10

Standard Test Method for Flexural Properties of Unreinforced and Reinforced Plastics and Electrical Insulating Materials by Four-Point Bending

1.1 This test method covers the determination of flexural properties of unreinforced and reinforced plastics, including high-modulus composites and electrical insulating materials in the form of rectangular bars molded directly or cut from sheets, plates, or molded shapes. These test methods are generally applicable to rigid and semirigid materials. However, flexural strength cannot be determined for those materials that do not break or that do not fail in the outer fibers. This test method utilizes a four point loading system applied to a simply supported beam.

1.2 This test method may be used with two procedures:

1.2.1 Procedure A, designed principally for materials that break at comparatively small deflections.

1.2.2 Procedure B, designed particularly for those materials that undergo large deflections during testing.

1.2.3 Procedure A shall be used for measurement of flexural properties, particularly flexural modulus, unless the material specification states otherwise. Procedure B may be used for measurement of flexural strength.

1.3 Comparative tests may be run according to either procedure, provided that the procedure is found satisfactory for the material being tested.

1.4 The values stated in SI units are to be regarded as the standard. The values provided in parentheses are for information only.

1.5 This standard does not purport to address all of the safety concerns, if any, associated with its use. It is the responsibility of the user of this standard to establish appropriate safety and health practices and determine the applicability of regulatory limitations prior to use.

Note 1—This test method is equivalent to ISO 14125 (Method B).

Extracted, with permission, from ASTM D6264 Standard Test Method for Measuring the Damage Resistance of a Fiber-Reinforced Polymer-Matrix Composite to a Concentrated Quasi-Static Indentation Force, copyright ASTM International, 100 Barr Harbor Drive, West Conshohocken, PA 19428. A copy of the complete standard may be purchased from ASTM International, www.astm.org.