

COMPRESSION SUBPRESS FOR AXIAL COMPRESSION (SS)

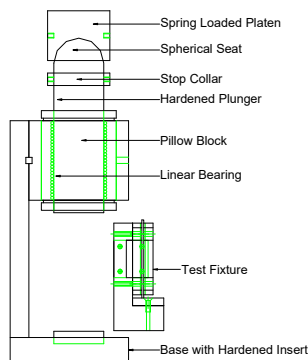

Specimen	Width	0.75" to 0.500" ± 0.005 " reduced gauge section
	Thickness	0.030" to 0.125"
	Length	3.130" ± 0.005 "
Fixture	Construction	Stainless steel
	Temperature	-240 to 600°F (-152 to 318°C)
	Mounting	Platen to platen
	Capacity	10,000 lbs
	Weight	25 lbs
	Dimensions	5" x 4" x 12" approximately
	Standard	Manufactured in accordance with ASTM D695.

Model No. ASTM.D0695.20 - Compression Subpress for Axial Compression (SS)

The subpress consists of a support, a frame, the guides, the plunger, and a recess that holds the lower hardened block. The upper and lower hardened blocks will be 2" diameter and ground flat and parallel (0.001 in.). The plunger will be guided by twin precision ball bearings and loaded through the plunger. The load is applied through the plunger that has a radius at the end with a spring loaded platen. The hardened plunger and spring loaded platen with radius socket will remove any misalignment of the testing machine. Constructed of stainless steel in accordance with ASTM D695.

MODEL NO. ASTM.D0695.20

COMPRESSION

ACCESSORIES

Model No. ASTM.D0695.10 - Compression anti-buckling fixture

Model No. BOEI.07260.31- Modified D695 test fixture

Lower fixture attachment is supported on a platen or flat surface of the test machine. (Common adapter sizes include:)

Model No. PLAT.RF061.10 - 6" Diameter Round Fixed Compression Platen

Model No. PLAT.RA061.10 - 6" Diameter Round Articulating Compression Platen

Model No. PLAT.SF061.10 - 6" Square Fixed Compression Platen

Model No. PLAT.SA061.10 - 6" Square Articulating Compression Platen

Model No. M03S36 - 1.25" Male Clevis (Type D) to 1" -14 Threaded Stud

SPARE PARTS

SPA.D0695.2001- Replacement Bearing

REFERENCE DOCUMENT AND TEST METHOD SCOPE:

Scope <http://www.astm.org/Standards/D695.htm>

ASTM D695-15

Standard Test Method for Compressive Properties of Rigid Plastics

1.1 This test method covers the determination of the mechanical properties of unreinforced and reinforced rigid plastics, including high-modulus composites, when loaded in compression at relatively low uniform rates of straining or loading. Test specimens of standard shape are employed. This procedure is applicable for a composite modulus up to and including 41,370 MPa (6,000,000 psi).

1.2 The values stated in SI units are to be regarded as the standard. The values in parentheses are for information only.

Note 1—For compressive properties of resin-matrix composites reinforced with oriented continuous, discontinuous, or cross-ply reinforcements, tests may be made in accordance with Test Method D3410/D3410M.

1.3 This standard does not purport to address all of the safety concerns, if any, associated with its use. It is the responsibility of the user of this standard to establish appropriate safety and health practices and determine the applicability of regulatory limitations prior to use. A specific precautionary statement is given in 13.1.

Note 2—This test method is technically equivalent to ISO 604.

Extracted, with permission, from ASTM D695 Standard Test Method for Compressive Properties of Rigid Plastics, copyright ASTM International, 100 Barr Harbor Drive, West Conshohocken, PA 19482. A copy of the complete standard may be purchased from ASTM International, www.astm.org.