

5,000 LBS CAPACITY SNUBBING TYPE WIRE TENSION GRIPS FOR UP TO 0.25" WIRE

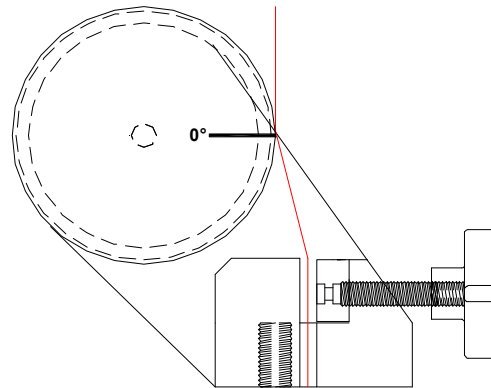

Specimen:	Diameter	0.25"
Fixture:	Construction	High strength steel with protective finish
	Temperature	-120 to 250°F (-85 to 122°C)
	Mounting	1/2"-20 threaded couplings
	Capacity	5,000 lbs
	Weight	Approximately 20 lbs
	Dimensions	2" x 12" x 2"
	Standard	Manufactured in accordance with ASTM A370 and E8

Model No. ASTM.A0370.61 - 5,000 Pound Snubbing grips

Grips that will accept Wire, Rod and Bar with diameters up to 0.250".

The grip has a stationary positive screw clamp to secure the ends of the test specimen. Supplied with 1/2"-20 threaded couplings. Constructed of high strength steel with a protective black oxide finish in accordance with ASTM A370.

MODEL NO. ASTM.A0370.61

MECHANICAL, STEEL, ASTM, SNUBBING, WIRE,

ACCESSORIES

Upper and lower fixture attachment is supplied with 1/2" -20 female coupling (Common adapter sizes include):

Model No. M01S21 - 1/2" Male Clevis (Type B) to 1/2" -20 Threaded Stud
Model No. M02S21 - 5/8" Male Clevis (Type C) to 1/2" -20 Threaded Stud
Model No. M03S21 - 1.25" Male Clevis (Type D) to 1/2" -20 Threaded Stud
Model No. M12S21 - 12mm Male Clevis (Type O) to 1/2" -20 Threaded Stud
Model No. S36S21 - 1" -14 to 1/2" -20 Threaded Step Stud
Model No. LN21 - 1/2" -20 Threaded Locking Nut with Knurled OD

SPARE PARTS

Please contact us for spare or replacement parts

REFERENCE DOCUMENT AND TEST METHOD SCOPE:

<http://www.astm.org/Standards/A370.htm>

ASTM A370 - 15

Standard Test Methods and Definitions for Mechanical Testing of Steel Products

1.1 These test methods cover procedures and definitions for the mechanical testing of steels, stainless steels, and related alloys. The various mechanical tests herein described are used to determine properties required in the product specifications. Variations in testing methods are to be avoided, and standard methods of testing are to be followed to obtain reproducible and comparable results. In those cases in which the testing requirements for certain products are unique or at variance with these general procedures, the product specification testing requirements shall control.

1.2 The following mechanical tests are described: (Sections)

Tension - 6 to 14, Bend - 15, Hardness - 16, Brinell - 17, Rockwell - 18, Portable - 19, Impact - 20 to 29, Keywords - 30.

1.3 Annexes covering details peculiar to certain products are appended to these test methods as follows: (Annex)

Bar Products - A1.1, Tubular Products - Annex A2, Fasteners - Annex A3, Round Wire Products - Annex A4, Significance of Notched-Bar Impact Testing - Annex A5, Converting Percentage Elongation of Round Specimens to Equivalents for Flat Specimens - Annex A6, Testing Multi-Wire Strand - Annex A7, Rounding of Test Data - Annex A8, Methods for Testing Steel Reinforcing Bars - Annex A9, Procedure for Use and Control of Heat-Cycle Simulation - Annex A10.

1.4 The values stated in inch-pound units are to be regarded as the standard.

1.5 When this document is referenced in a metric product specification, the yield and tensile values may be determined in inch-pound (ksi) units then converted into SI (MPa) units. The elongation determined in inch-pound gauge lengths of 2 or 8?in. may be reported in SI unit gauge lengths of 50 or 200 mm, respectively, as applicable. Conversely, when this document is referenced in an inch-pound product specification, the yield and tensile values may be determined in SI units then converted into inch-pound units. The elongation determined in SI unit gauge lengths of 50 or 200 mm may be reported in inch-pound gauge lengths of 2 or 8?in., respectively, as applicable.

1.5.1 The specimen used to determine the original units must conform to the applicable tolerances of the original unit system given in the dimension table not that of the converted tolerance dimensions.

NOTE 1: This is due to the specimen SI dimensions and tolerances being hard conversions when this is not a dual standard. The user is directed to Test Methods A1058 if the tests are required in SI units.

1.6 Attention is directed to ISO/IEC 17025 when there may be a need for information on criteria for evaluation of testing laboratories.

1.7 This standard does not purport to address all of the safety concerns, if any, associated with its use. It is the responsibility of the user of this standard to establish appropriate safety and health practices and determine the applicability of regulatory limitations prior to use.

Material Testing Technology

420 Harvester Court - Wheeling, IL. 60090 - Ph: (847) 215-7448 Fax: (847) 215-7449 E-mail: sales@mttusa.net